

INSTALLATION and USE GUIDELINE SCHROTH INTERIOR / RACING NET

Edition: 06/2020
Part No: EA 14.2

Thank you for choosing our product.

Please follow the simple installation instructions below:

- 1) Install and attach net, using the current FIA 8863-2013 Racing Net Installation Specification Guide [see www.fia.com]. All attachment points must be capable of handling a 2250lbf [10kN] applied pull load. The front strap can be attached with wrap around option, using the 3-bar slide.
- 2) Adjust net using the 3-bar slides to get the net as tight as possible. (see "Wrapping of Net")
- 3) Make sure you are satisfied with the location and attach points of the net. Make sure the attachment points fulfill the FIA Regulations. (see current version of FIA 8863-2013 Racing Net Installation Specification Guide)
- 4) The net shall have a minimum of two vertical webbing straps in contact with the seat-side-head.

WARNING

Risk of severe injuries or death.

Follow all FIA Safety Guidelines & Regulations and heed all Instructions and Warnings of this Installation and Use Guideline!

INSTALLATION PER FIA 8863-2013

It is recommended that, where possible, the upper-strap of the racing net is positioned *inside* the seat-side-head as shown in Figure 1.

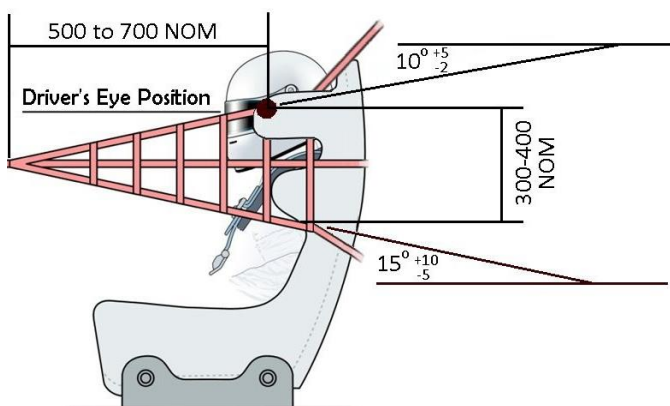

Figure 1: Positioning of net with upper-strap *inside* the seat-side-head [applicable to both Single-front-attachment design and to Dual-front-attachment design]

Note: NOM dimensions for guidance only

Where the above position cannot be achieved, for instance, if the seat-side-head and seat-side-shoulder of the seat are integrated, the upper-strap may be positioned *outside* the seat-side-head as shown in Figure 2.

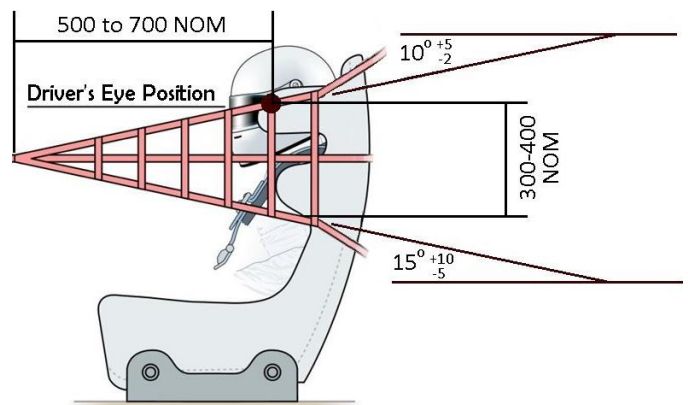

Figure 2: Positioning of net with upper-strap *outside* the seat-side-head [applicable to both Single-front-attachment design and to Dual-front-attachment design]

Note: NOM dimensions for guidance only

When viewed from the side

- 3.1 the upper-strap¹ shall pass through the eye position +80mm(Z)-15mm(Z) and shall be angled at 10° +5/-2 relative to the horizontal plane. Additionally, the upper-strap¹ shall not run more than 40mm above the top edge of the seat-side-head. And the upper-strap² shall not run below the bottom edge of the seat-side-head.
- 3.2 the middle-strap shall be horizontal ±10° relative to the horizontal plane.
- 3.3 the lower-strap³ shall run along the bottom edge of the seat-side-shoulder +0(Z)-100(Z) and shall be angled at 15° +10/-5 relative to the horizontal plane.
- 3.4 the merge point will, typically, be 500-700mm forward of the driver's eye position.
- 3.5 the net shall have a minimum of two vertical webbings in contact with the seat-side-head.
- 3.6 the eye position of all drivers shall be marked on the external side of the seat-side-head support.

Dual-front-attachment only [see Figure 3]

- 3.7 When viewed from the side, the forward strap shall be horizontal +0 - 30deg
- 3.8 When viewed from the side, the upper strap shall be vertical +45deg (forward) - 20deg

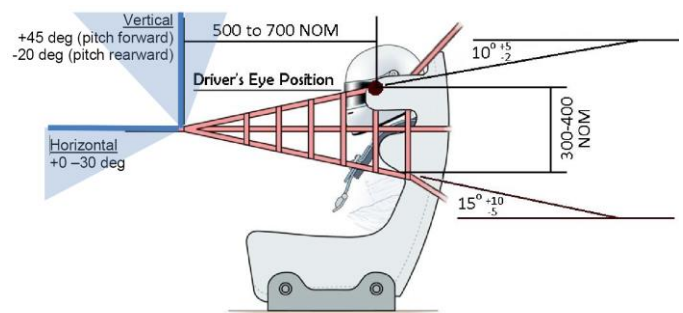

Figure 3: Positioning of net with Dual-front-attachment design

- ¹ measured from top edge of upper-strap
- ² measured from bottom edge of upper-strap
- ³ measured from bottom edge of lower-strap

Attaching the front and rear straps of the racing net

When viewed from above

- 4.1 the front straps shall be parallel to the longitudinal axis of the car $\pm 6^\circ$ as shown in **Figure 4**.
- 4.2 the tension in the racing-net shall be such that, at any x-position of each upper, middle and lower strap of the triangle, a load of 50N applied in a lateral direction away from the driver shall produce a maximum deformation of 50mm.
- 4.3 in order to minimise any potential interference between the front-strap and the driver's arms or hands, a bungee may be fitted to pre-tension the net away from the driver. Such an installation should not impede the driver's egress when the quick-release of the net is disconnected. Furthermore, the requirements of 4.1 shall be satisfied before the bungee is fitted.

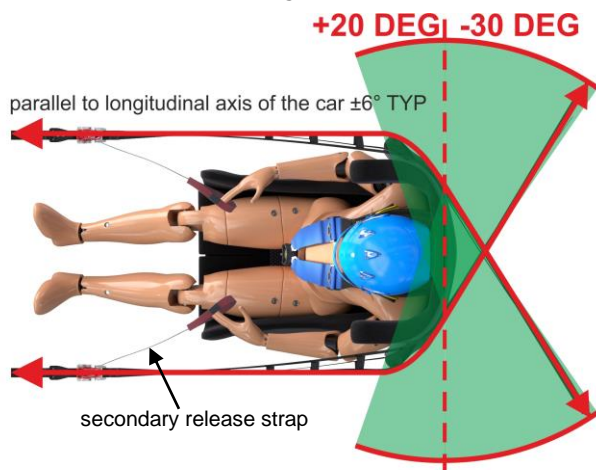

Figure 4: Attachment of front and rear straps

SPECIFIC REQUIREMENTS FOR RACING NETS ATTACHED TO AN FIA-APPROVED 8862-2009 SEAT

The three rear-straps may be attached to an FIA-approved 8862-2009 seat providing it has the relevant marking on the label: "Valid for attaching racing nets (optional)".

Each of the three rear-straps shall attach to the seat in the same way the net has been homologated and as per the seat manufacturer's instructions.

Each of the three rear-straps shall be positioned in such a way that the strap cannot slide downward.

The rearmost vertical strap must intersect the seat-side-shoulder in side-view.

The net straps shall not be twisted by the seat guides and attachments or constrained in a way that is not prescribed in the seat and net manufacturers' instructions.

INSTALLATION AND LOADS

Load Case for Attachment Points

The front-straps of each Racing Net shall have a single attachment to the car. The attachment shall be designed to sustain 10kN MIN with 15mm MAX deformation.

Each rear-strap of the Racing Net shall attach to the car at a separate position. The attachments shall be designed to sustain 10kN MIN with 15mm MAX deformation.

Fitment of handed Nets

Nets are typically handed; left or right. The net horizontal webbing shall be located towards the driver, to provide the smoothest surface for the helmet to glide on, with the net vertical webbing located away from the driver.

Quick release mechanism

When the driver is seated in his racing position with seatbelts tightened, he must be able to reach and open the quick release mechanism of both nets.

In addition, the position of the quick release mechanism must allow rescue crews to easily access and open them.

Positioning main triangle of the racing net

In order to ensure optimal protection, it is imperative that the driver is, first, correctly fitted to the FIA-approved 8862 or 8855 seat.

Once this has been achieved, the FIA-approved 8863 Racing Net shall be installed as detailed below; with the upper strap positioned relative to driver's eye position (with additional limits in Z relative to the seat-

side-head) and the lower-strap positioned relative to the seat-side-shoulder.

WRAPPING OF NET

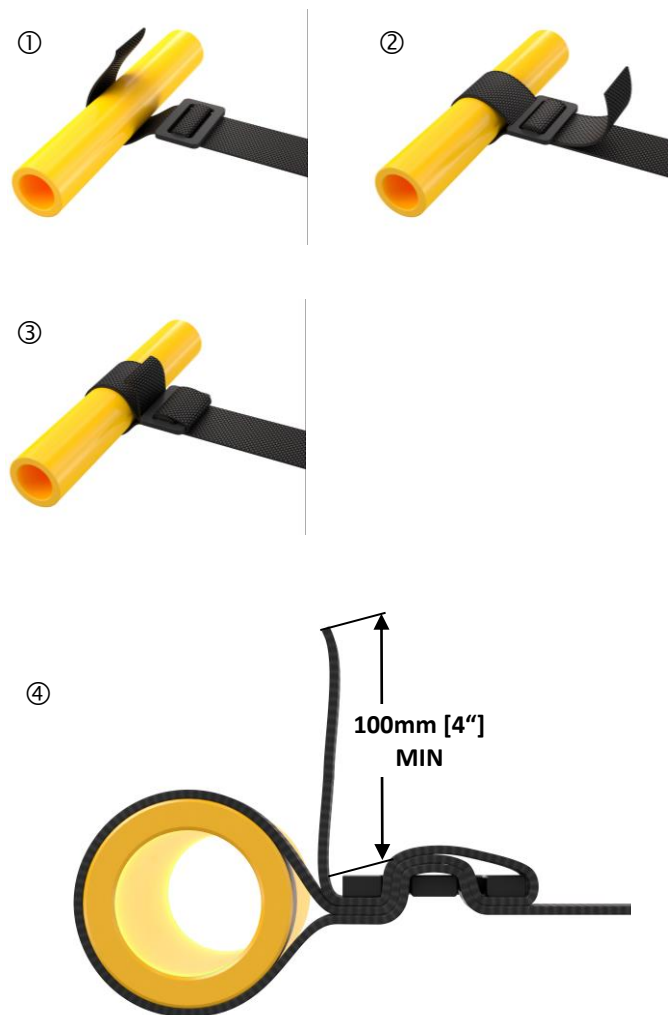

NET OVERVIEW
PUSH BUTTON BUCKLE RELEASE



To release or in an event of an emergency requiring exit or extrication, push red release button on front of the automotive style push button buckle.

[Optional stabilization fixation to rollcage – this fixation is not load bearing.]



DOUBLE TAKE RATCHET SYSTEM RELEASE

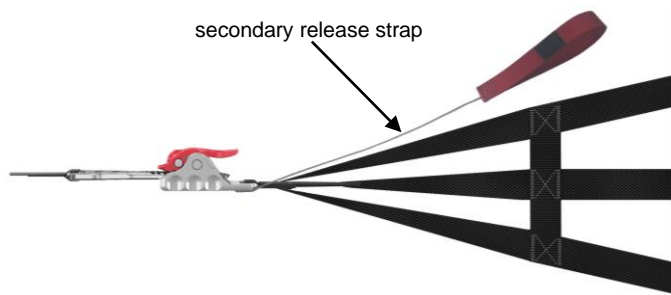

or pull secondary release strap

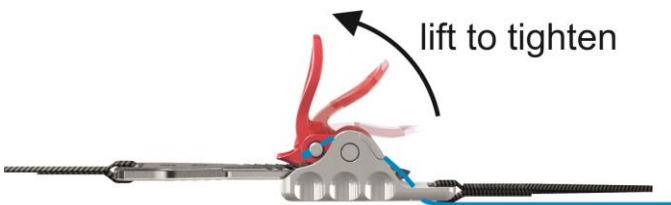

5 POINT NET BUCKLE SYSTEM



FIXATIONS TO ROLLAGE

Optional stabilizing fixation to rollcage – this fixation is not load bearing.
 Latch/Tongue and Ratchet should be installed upwards at a $90^\circ \pm 15^\circ$ orientation.

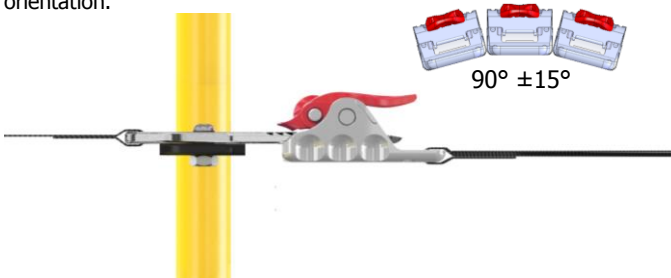

this figure shows the right 5 Point Net Buckle System 09577

5 POINT NET BUCKLE SYSTEM RELEASE

Press red PRESS button...



this figure shows the **correct** installation of the right 5 Point Net Buckle System 09577



this figure shows the **wrong** installation of the right 5 Point Net Buckle System 09577



this figure shows the **correct** installation of the left 5 Point Net Buckle System 09077



this figure shows the **wrong** installation of the left 5 Point Net Buckle System 09077

.... and all latches, except one, will release from the buckle



this figure shows the **correct** installation of the right 5 Point Net Buckle System 09577



this figure shows the **wrong** installation of the right 5 Point Net Buckle System 09577



this figure shows the **correct** installation of the left 5 Point Net Buckle System 09077



this figure shows the **wrong** installation of the left 5 Point Net Buckle System 09077

ADDRESSES AND COPYRIGHTS

SCHROTH Safety Products GmbH

Im Ohl 14
59757 ARNSBERG
GERMANY

Phone: +49 (0) 2932-9742-0
FAX: +49 (0) 2932-9742-42
eMail: germany@schroth.com
www.schroth.com

Warranty issues or questions in North America can be directed to our importer

HMS Motorsport, 119 Bevan Drive, Mooresville, NC 28115 or by calling toll free 800-884-2358.

SCHROTH reserves the right to incorporate any technical changes or further development in this product without notice. Our web site www.schroth.com will inform you about actual instructions and products. Also regional representatives and further importers are listed by countries.

REGISTERED TRADEMARKS:

SCHROTH® and **SCHROTH Racing®** are international registered trademarks of SCHROTH Safety Products GmbH, Im Ohl 14, 59757 Arnsberg, Germany.

COPYRIGHTS:

The copyrights of this "Installation and Use Guideline" are property of SCHROTH Safety Products GmbH, Im Ohl 14, 59757 Arnsberg, Germany.

Copyright of this in part or in whole, on paper, on film or electronically is allowed only after written permission by SCHROTH Safety Products GmbH, Im Ohl 14, 59757 Arnsberg, Germany.